

## EA180 Servo System Selection Guide

Reliable drives and solutions by technology



### Shenzhen SINEE Electric Co., Ltd.

Address: Building 7#, Antuoshan High-tech Industrial Park, Xinsha Road, Baoan District, Shenzhen  
Tel: 86-0755-86267221  
Website: [www.sineedrive.com](http://www.sineedrive.com)  
Ver: 2017/12-100



# COMPANY PROFILE



- Marketing Office
- SINEE Service Centre

SINEE has the customer service centers in 19 cities of China, such as Shenyang, Shijiazhuang, Zhengzhou, Wuhan, Chongqing, Wuxi, Hangzhou, Shenzhen etc.

Founded in 2003 with the registered capital ¥64.50 million(around USD10 million), Shenzhen SINEE Electric Co., Ltd. is a professional industrial automation product and solution supplier; SINEE is focusing on researching, developing, producing and distributing electric transmission automation products, and serving the medium and high-end equipment manufacturers and system integrators.

SINEE, a national new high-tech enterprise of China and a renowned brand enterprise of Shenzhen, is always insisting in the technology and product innovation strategy, and has developed and established multiple core technology platforms for the high-performance variable-frequency vector control, servo drive, elevator control, power electronics etc. Additionally by following strictly the IPD flow, SINEE is developing new products in the fields of frequency converter, servo system, electric automobile's drive system, elevator's drive controller etc. SINEE is making the customized special products and solutions for customers and has owned the rich systematic products serving the industries of building hoisting machinery, engineering machinery, petrochemical industry, cable equipment, printing and packaging, metal processing etc.

Stock name: SINEE Electric Stock code: 834933



深圳总部



武汉基地(在建设中)



# HONOR CERTIFICATION

- ◆ Renowned brand of Shenzhen
- ◆ One of 10 top national low-voltage variable frequency inverter brands
- ◆ Leading enterprise of Nanshan District, Shenzhen
- ◆ Backbone enterprise of prospering country with quality in Shenzhen
- ◆ One of Top 100 small and medium-sized enterprise based on self-dependent innovation in Shenzhen
- ◆ Co-compiling enterprise of two national standards
- ◆ ISO9001, IATF 16949 system certification
- ◆ CE certified for series standard products
- ◆ National-level high-tech technology enterprise
- ◆ Advanced member enterprise of Frequency Converter Association





# SINEE PRODUCT

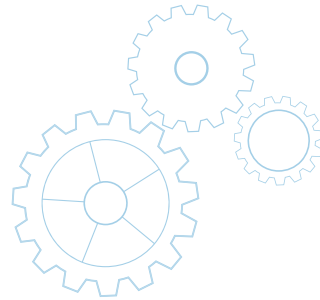





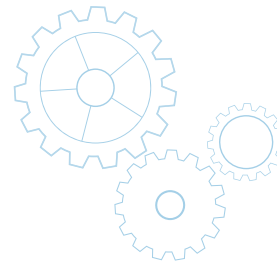

# SINEE CATALOG

Company profile	01
Honors & certification	02
Products	03
Catalogue	04
EA 180 product line introduction	05
EA180 servo system characteristics	07
09	EA 180E wiring diagram
11	EA 180C wiring diagram
13	EA 180 wiring diagram
15	Servo Drive
	Servo motor
	Accessories Combinations
16	EA 180 driver introduction
20	SER motor introduction
25	Cable introduction



## EA180 product line introduction

<p>Controller &amp; HMI</p>	 <p>The image shows a motion controller with the EtherCAT logo and three HMI monitors of different sizes.</p> <p>Motion controller</p> <p>HMI</p>
<p>Servo drive</p>	 <p>The image shows two servo drive units: EA180E and EA180C, with a motor attached to the EA180C.</p> <p>EA180E EtherCAT network type</p> <p>EA180C CANopen network type</p>
<p>Servo motor</p>	 <p>The image shows three different sizes of SER motor series servo motors.</p> <p>SER motor series</p>

<p>Controller &amp; HMI</p>	 <p>The image shows a PLC unit and three HMI monitors of different sizes.</p> <p>PLC</p> <p>HMI</p>
<p>Servo drive</p>	 <p>The image shows two servo drive units: EA180P and EA180, with a motor attached to the EA180.</p> <p>EA180P PROFINET network type (to be released)</p> <p>EA180 Analog &amp; pulse type</p>
<p>Servo motor</p>	 <p>The image shows two different sizes of SES motor series servo motors.</p> <p>SES motor series</p>

## EA180 servo system – technical characteristics

### High-speed response performance

- Up to 1.0KHz speed frequency response.
- Shortened positioning time.
- High-speed and high-accuracy real-time synchronous communication on basis of parallelized system design.

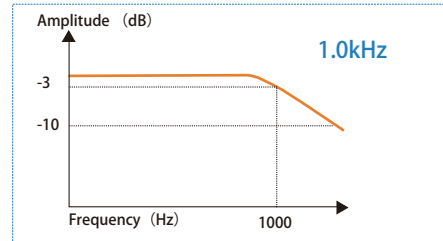

### Small Size

- Size similar to Panasonic A6 series drive, matched with SINEE SES servo motor, can help to minimize the system volume.



### High-accuracy positioning

- Encoder of 17 bit incremental and 23 bit absolute value, with the powerful control performance, can make the positioning accuracy less than 5 encoder pulses.

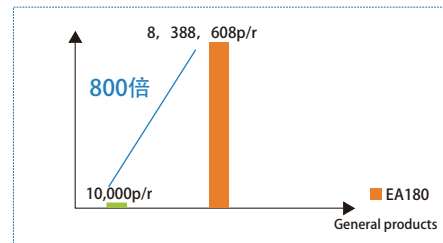

### Intelligent controls

- Intelligentized resonance suppression  
The system has four (4) high-frequency resonance suppression notch filters, two (2) of them are the FFT-based ones; the others are manual ones. Synchronously the vibration suppression filters are provided to minimize the vibration of long arm machine.
- Control gain switchover functions  
The control loop structure on the basis of PDFF may reduce overshooting efficiently. The parameter self-adjustment on the basis of inertia may enhance the site adaptability.

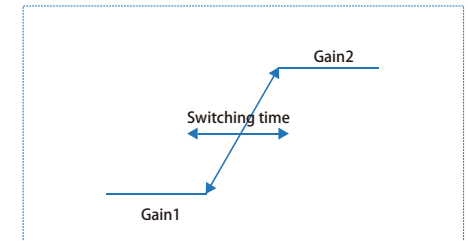
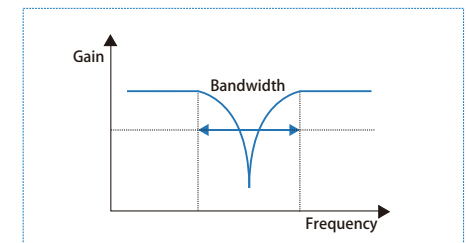

### Abundant product series

- Analog & pulse standard type and network type with EtherCAT or CANopen or RS485 protocol supported;
- 2500 ppr or serial type with 17 bit incremental or 23 bit absolute values encoder available



### High reliability

- Complete protection function and EMC design  
Protection function design on the basis of overall reliability of motor and driver; EMC design on the basis of graded optimization and system adaptability.
- High-performance motor material and technology ensure the system to run reliably  
Containing dysprosium-neodymium-ferroboron magnetic steel, high-strength shaft, Tamagawa encoder, large-size bearing, encapsulated by resin.

## EA180E Wiring for EtherCAT network type Servo system

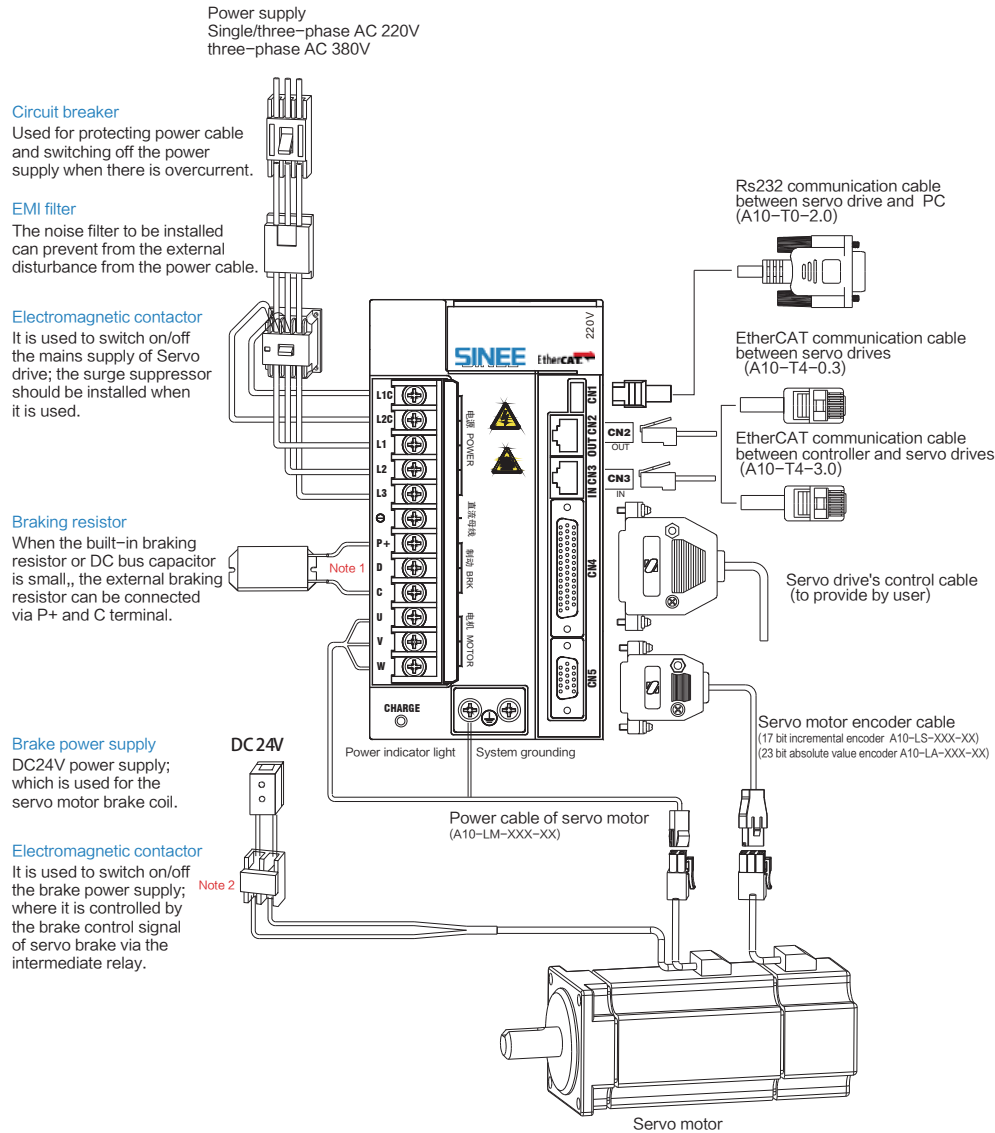

## EA180E Description for EtherCAT network Servo drive's terminal

CN 1 RS232 communication terminal

Pin No.	Signal name	Functions
1	RS232-RXD	RS232 signal receiving terminal
2	RS232-TXD	RS232 signal transmitting terminal
3	Reserved	Can not connect with any signal cable
4	GND	RS232 communication reference grounding

CN2, CN3 EtherCAT communication terminal

IN		OUT	
Pin No.	Signal name	Pin No.	Signal name
1	TD+	1	TD+
2	TD-	2	TD-
3	RD+	3	RD+
4	-	4	-
5	-	5	-
6	RD-	6	RD-
FG	Connector hood	FG	Connector hood

CN4 control terminal

Signal name	Pin No.	Default function	
DI1	5	P-OT	Positive drive Inhibited
DI2	20	N-OT	Negative drive Inhibited
DI3	4	ORPG	Homing detection signal
DI4	19	ALM-RST	Alarm fault reset
DI5	3	GAIN-SEL	Gain switch
DI6	18	J-SEL	Ratio of inertia changeover
DI7	2	P-CLR	Pulse error counter reset
DI8	17	INHIBIT	Pulse Inhibited
COM+	21	Digital input common positive port	
+24V	25/40	Internal 24V power supply, voltage range: +20V ~ 26V, maximum output current 200mA.	
COM	7/22/36		
+5V	6	+5V power supply, maximum output current: 50mA	
GND	29		
DO1	8	S-RDY+	Servo ready, connected as available for receiving S-ON signal
DO1-	37	S-RDY-	
DO2	23	BK+	Brake control signal
DO2-	38	BK-	
DO3	9	COIN+	Position arrival signal
DO3-	39	COIN-	
DO4	24	ALM+	Connected when there is fault
DO4-	10	ALM-	

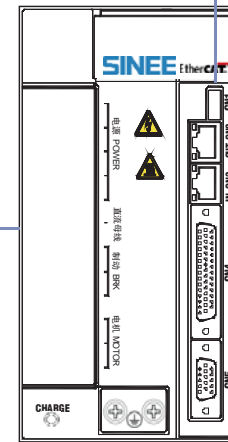

Main circuit terminals

Terminal mark	Terminal name
L1C, L2C	Control power input terminal
L1, L2, L3	Main circuit AC power input terminal
P+, D, C	Terminal connecting to external braking resistor
P+, ⊖	DC bus sharing terminal
U, V, W	Servo motor's connecting terminal
PE	Grounding

CN5 encoder terminal

Pin No.	Signal name
1	SD+
3	SD-
5	+5V
10	GND
15/enclosure	shielded layer



## EA180C Wiring for CANopen network type Servo system

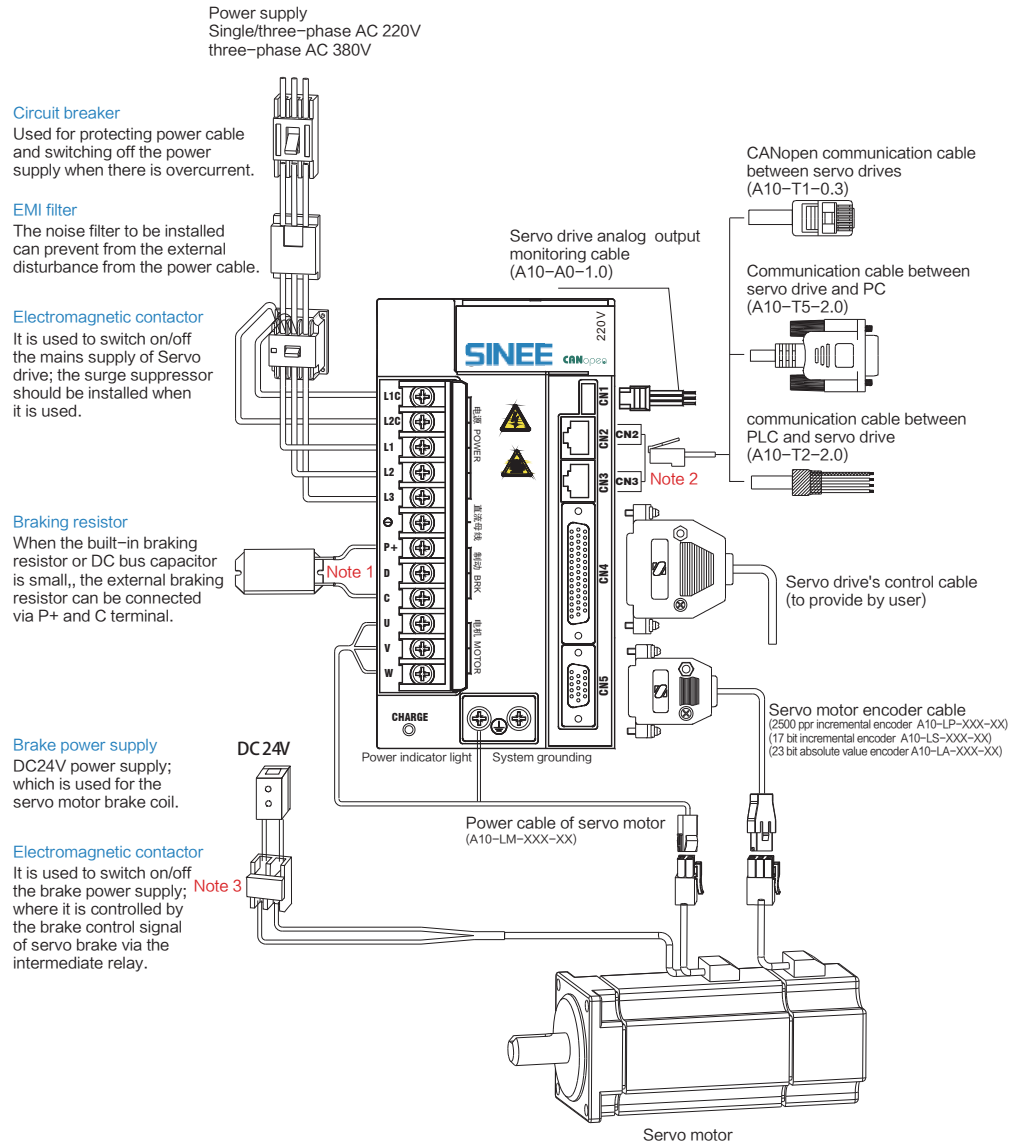

## EA180C Description for CANopen network Servo drive's terminal

### Main circuit terminals

Terminal mark	Terminal name
L1C, L2C	Control power input terminal
L1, L2, L3	Main circuit AC power input terminal
P+, D, C	Terminal connecting with external braking resistor
P+, ⊖	DC bus sharing terminal
U, V, W	Servo motor's connecting terminal
PE	Grounding

### CN 1 analog quantity monitoring terminal

Pin No.	Signal name	Functions
1	AO1	Analog output voltage: 0V-10V
2	AO2	Maximum output current: 1mA
3	GND	Analog output signal common earthing
4	Reserved	Can not connect with any signal cable

### CN2, CN3 communication terminal

Pin No.	Signal name	Function	Pin No.	Signal name	Function
1	RS485+	RS485 signal positive terminal	5	RS232-TXD	RS232 signal transmitting terminal
2	RS485-	RS485 signal negative terminal	6	GND	Communication signal reference grounding
3	GND	Communication signal reference grounding	7	CANH	CAN signal positive terminal
4	RS232-RXD	RS232 signal receiving terminal	8	CANL	CAN signal negative terminal

Note: CAN 2 and CN3 are the same.

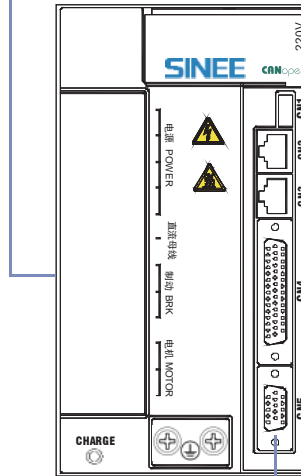

### CN4 control terminal

Signal name	Pin No.	Default function
DI1	5	S-ON Servo enabled
DI2	20	ALM-RST Alarm fault reset
DI3	4	P-CLR Pulse error counter reset
DI4	19	P-OT Inhibit positive drive
DI5	3	N-OT Inhibit Negative drive
DI6	18	INHIBIT Pulse Inhibited
DI7	2	GNUM0 Electronic gear ratio - selected numerator 0
DI8	17	GNUM1 Electronic gear ratio - selected numerator 1
COM+	21	DI input common positive port
+24V	25/40	Internal 24V power supply, voltage range: +20V ~ 26V, maximum output current 200mA.
COM	7/22/36	
+5V	6	+5V power supply, maximum output current: 50mA
GND	29	
DO1	8	S-RDY+ Servo ready, connected as available for receiving S-ON signal
DO1-	37	S-RDY-
DO2	23	BK+
DO2-	38	BK-
DO3	9	COIN+
DO3-	39	COIN-
DO4	24	ALM+
DO4-	10	ALM-
PA+	28	Pulse A frequency division output positive
PA-	13	Pulse A frequency division output negative
PB+	12	Pulse B frequency division output positive
PB-	27	Pulse B frequency division output negative
PZ+	11	Pulse Z frequency division output positive
PZ-	26	Pulse Z frequency division output negative
OCZ	35	Pulse Z open-collector output, maximum allowable input current 40mA
GND	14	

### CN5 encoder terminal

Pin No.	Default function
1	SD+
3	SD-
5	+5V
10	GND
15/enclosure	shielded layer

## EA180 Wiring for analog and pulse command type servo system

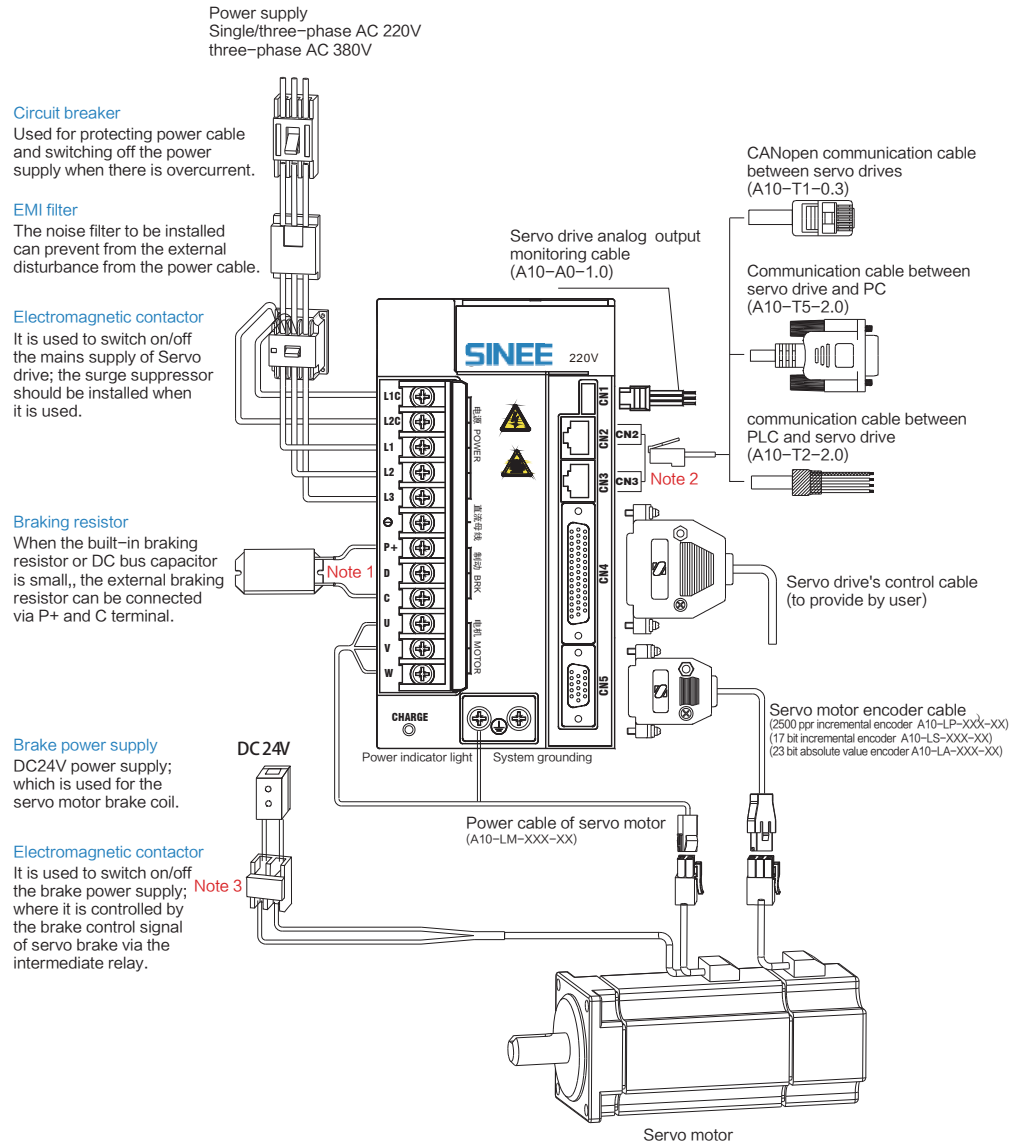

## EA180 Description for analog and pulse command type servo drive's terminal

### Main circuit terminals

Terminal mark	Terminal name
L1C, L2C	Control power input terminal
L1, L2, L3	Main circuit AC power input terminal
P+, D, C	Terminal connecting with external braking resistor
P+, ⊖	DC bus sharing terminal
U, V, W	Servo motor's connecting terminal
PE	Grounding

### CN1 analog quantity monitoring terminal

Pin No.	Signal name	Functions
1	AO1	Analog output voltage: 0V~10V Maximum output current: 1mA
2	AO2	
3	GND	Analog output signal common earthing
4	Reserved	Can not connect with any signal cable

### CN2, CN3 communication terminal

Pin No.	Signal name	Function	Pin No.	Signal name	Function
1	RS485+	RS485 signal positive terminal	5	RS232-TXD	RS232 signal transmitting terminal
2	RS485-	RS485 signal negative terminal	6	GND	Communication signal reference grounding
3	GND	Communication signal reference grounding	7	-	-
4	RS232-RXD	RS232 signal receiving terminal	8	-	-

Note: CAN 2 and CN3 are the same.

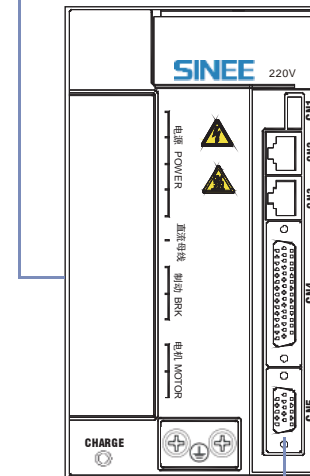

### CN4 control terminal

Signal name	Pin No.	Default function
<b>Digital input</b>		
DI1	5	S-ON Servo enabled
DI2	20	ALM-RST Alarm fault reset
DI3	4	P-CLR Pulse error counter reset
DI4	19	P-OT Inhibit positive drive
DI5	3	N-OT Inhibit Negative drive
DI6	18	INHIBIT Pulse inhibited
DI7	2	GNUM0 Electronic gear ratio - selected numerator 0
DI8	17	GNUM1 Electronic gear ratio - selected numerator 1
COM+	21	Digital input common positive port
<b>Power supply</b>		
+24V	25/40	Internal 24V power supply, voltage range: +20V ~ 26V, maximum output current 200mA.
COM	7/22/36	
+5V	6	+5V power supply, maximum output current: 50mA
GND	29	
<b>Digital output</b>		
DO1	8	S-RDY+ Servo ready, connected as available for receiving S-ON signal
DO1-	37	S-RDY-
DO2	23	BK+ Brake control signal
DO2-	38	BK-
DO3	9	COIN+ Position arrival signal
DO3-	39	COIN-
DO4	24	ALM+ Connected when there is fault
DO4-	10	ALM-
<b>Frequency division output</b>		
PA+	28	Pulse A frequency division positive
PA-	13	Pulse A frequency division negative
PB+	12	Pulse B frequency division positive
PB-	27	Pulse B frequency division negative
PZ+	11	Pulse Z frequency division positive
PZ-	26	Pulse Z frequency division negative
OCZ	35	Pulse Z open-collector output, maximum allowable input current 40mA
GND	14	
<b>Analog input</b>		
AI1	15	Analog quantity input signal, resolution 12 bits, maximum allowable input voltage ±12V.
AI2	30	
GND	29	Analog input signal grounding
<b>Pulse position command</b>		
PULHIP	1	Position pulse user 24V power supply
PULSE+	33	Position pulse command +
PULSE-	34	Position pulse command -
PULHIS	16	Directional pulse user 24V power supply
SIGN+	31	Differential position's directional command
SIGN-	32	Differential position's directional command

### CN5 encoder terminal

Pin No.	Signal name		Pin No.	Signal name	
	2500 ppr encoder	Serial encoder		2500 ppr encoder	Serial encoder
1	Z+	SD+	9	W-	-
2	U+	-	10	GND	GND
3	V+	SD-	11	B+	-
4	W+	-	12	B-	-
5	+5V	+5V	13	A+	-
6	Z-	-	14	A-	-
7	U-	-	15/enclosure	Shielded layer	Shielded layer
8	V-	-	-	-	-



EA180 Servo Drive & Servo motor & Accessories Combinations

Motor model	Motor's rated power (W)	Servo drive model	Encoder cable	Motor power cable
SES04-0R1-30-2G□□□	100	EA180□-1R6-1A	A10-LF-A000-m	A10-LM-A010-m (Servo motor power cable)
SER06-0R2-30-2A□□□	200			
SER06-0R4-30-2A□□□	400	EA180□-2R5-1A	A10-LP-A000-m (2500ppr AMP joint)	A10-LZ-A005-m (Braking power cable of motor with brake)
SER08-1R0-30-2A□□□	1000			
SER08-0R7-30-2A□□□	750	EA180□-5R5-2A	A10-LP-H100-m (2500ppr aviation joint)	A10-LM-H120-m (Servo motor power cable)  A10-LB-H120-m (Power cable of motor with brake + braking power cable)
SER08-0R7-20-2A□□□				
SER09-0R7-30-2A□□□				
SER11-0R6-30-2A□□□	EA180□-2R5-1A			
SER11-1R2-30-2A□□□	1200	EA180□-7R6-2A		
SER11-1R8-30-2A□□□	1800	EA180□-7R6-2A		
SER11-1R0-20-2A□□□	1000			
SER13-1R0-10-2A□□□				
SER13-1R0-20-2A□□□				
SER13-1R0-30-2A□□□				
SER13-0R7-20-2A□□□	750	EA180□-5R5-2A		
SER13-1R5-20-2A□□□	1500	EA180□-010-2A		
SER13-1R5-10-3A□□□		EA180□-8R4-3A		
SER13-1R5-20-3A□□□		EA180□-5R4-3A		
SER13-1R5-30-3A□□□				
SER13-2R0-20-3A□□□	2000	EA180□-8R4-3A		
SER13-2R0-30-3A□□□	3000	EA180□-012-3A		
SER13-3R0-20-3A□□□				
SER13-3R0-30-3A□□□				
Motor model	Motor's rated power (W)	Servo drive model	Encoder cable	Motor power cable
SES04-0R1-30-2B□□□	100	EA180□-1R6-1B	A10-LS-A000-m (17 bit incremental type)	A10-LM-A010-m (Servo motor power cable)
SER06-0R2-30-2B□□□	200			
SER06-0R4-30-2B□□□	400	EA180□-2R5-1B	A10-LZ-A005-m (Braking power cable of motor with brake)	
SER08-1R0-30-2B□□□	1000			
SER08-0R7-30-2B□□□	750	EA180□-5R5-2B	A10-LS-H100-m (17 bit incremental type) (aviation joint) (without battery)	A10-LM-H120-m (Servo motor power cable)  A10-LB-H120-m (Power cable of motor with brake + braking power cable)
SER08-0R7-20-2B□□□				
SER09-0R7-30-2B□□□				
SER11-0R6-30-2B□□□	600	EA180□-2R5-1B		
SER11-1R2-30-2B□□□	1200	EA180□-7R6-2B		
SER11-1R8-30-2B□□□	1800	EA180□-7R6-2B		
SER11-1R0-20-2B□□□	1000			
SER13-1R0-10-2B□□□				
SER13-1R0-20-2B□□□				
SER13-1R0-30-2B□□□				
SER13-0R7-20-2B□□□	750	EA180□-5R5-2B		
SER13-1R5-20-2B□□□	1500	EA180□-010-2B		
SER13-1R5-10-3B□□□		EA180□-8R4-3B		
SER13-1R5-20-3B□□□		EA180□-5R4-3B		
SER13-1R5-30-3B□□□				
SER13-2R0-20-3B□□□	2000	EA180□-8R4-3B		
SER13-2R0-30-3B□□□	3000	EA180□-012-3B		
SER13-3R0-20-3B□□□				
SER13-3R0-30-3B□□□				
SER18-4R5-15-3F□□□ <sup>*1</sup>	4500	EA180□-018-3B		A10-LM-M220-m (Servo motor power cable) The power cable of brake is not provided
SER18-5R6-15-3F□□□ <sup>*1</sup>	5600	EA180□-021-3B		A10-LM-M240-m (Servo motor power cable) The power cable of brake is not provided
SER18-7R5-15-3F□□□ <sup>*1</sup>	7500	EA180□-026-3B		

Note: As for 180mm flange motor, the absolute value type is only provided; which can be used as the incremental type; however the power cable must be matched.

EA180 Servo Drive & Servo motor & Accessories Combinations

Motor model	Motor's rated power (W)	Servo drive model	Encoder cable	Motor power cable
SES04-0R1-30-2F□□□	100	EA180□-1R6-1B	A10-LA-A000-m (23 bit absolute type) (AMP joint) (with battery)	A10-LM-A010-m (Servo motor power cable)
SER06-0R2-30-2F□□□	200			
SER06-0R4-30-2F□□□	400	EA180□-2R5-1B		A10-LZ-A005-m (Braking power cable of motor with brake)
SER08-1R0-30-2F□□□	1000			
SER08-0R7-30-2F□□□	750	EA180□-5R5-2B	A10-LA-H100-m (23 bit absolute type) (aviation joint) (with battery)	A10-LM-H120-m (Servo motor power cable)  A10-LB-H120-m (Power cable of motor with brake + braking power cable)
SER08-0R7-20-2F□□□				
SER11-1R2-30-2F□□□	1200	EA180□-7R6-2B		
SER11-1R8-30-2F□□□	1800	EA180□-7R6-2B		
SER11-1R0-20-2F□□□	1000			
SER13-1R0-10-2F□□□				
SER13-1R0-20-2F□□□				
SER13-1R0-30-2F□□□		1500		
SER13-0R7-20-2F□□□	EA180□-010-2B			
SER13-1R5-20-2F□□□	EA180□-8R4-3B			
SER13-1R5-10-3F□□□	EA180□-5R4-3B			
SER13-1R5-20-3F□□□	2000	EA180□-8R4-3B		
SER13-1R5-30-3F□□□				
SER13-2R0-20-3F□□□	3000	EA180□-012-3B		
SER13-2R0-30-3F□□□				
SER18-3R0-15-3F□□□				
SER18-3R0-15-3F□□□	4500	EA180□-018-3B		
SER18-4R5-15-3F□□□				
SER18-5R6-15-3F□□□	5600	EA180□-021-3B		
SER18-7R5-15-3F□□□	7500	EA180□-026-3B		

EA 180 Servo drive model number description

EA 180 □ - 8R4 - 3 B XX

① ② ③ ④ ⑤ ⑥ ⑦

① Product: Servo drive	④ Rated output current: 1R6 — 1.6A ; 026 — 26A	⑥ Type of encoder A: pulse incremental type B: serial communication type
② Series: 180 series	⑤ Rated power supply and voltage 1. Single-phase AC220V 2. Three-phase AC220V 3. Three-phase AC380V	⑦ Special specifications
③ Empty: Analog & pulse type E: EtherCAT network type C: CANopen network type P: PROFINET network type		

Voltage	Drive model	Rated motor power (kW)	Rated current (A)	Max. current (A)	Structure	Adapting motor encoder			
Single/three-phase 220V	EA180□-1R6-1□	0.2	1.6	5.6	SIZE A/B	□-A : 2500 ppr incremental type □-B : 17 bit incremental type 23 bit absolute value			
	EA180□-2R5-1□	0.4	2.5	9.0					
	EA180□-5R5-2□	0.75	5.5	16.9					
	EA180□-7R6-2□	1.0	7.6	17					
Three-phase 220V	EA180□-010-2□	1.5	10	30	SIZE C				
	EA180□-5R4-3□	1.5	5.4	14					
	EA180□-8R4-3□	2.0	8.4	20					
	EA180□-012-3□	3.0	12	30					
	Three-phase 380V	EA180□-018-3□	4.5	18			45	SIZE D	□-A : 2500 ppr incremental type □-B : 17 bit incremental type 23 bit absolute value
		EA180□-021-3□	5.6	21			55		
		EA180□-026-3□	7.5	26			65		

## EA 180 series Servo drive size

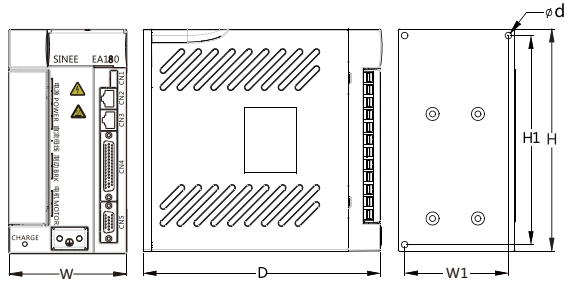

Structure	SIZE A	SIZE B	SIZE C	SIZE D
W(mm)	44	65	90	110
H(mm)	168	170	170	283
D(mm)	148	171	184	233
W1(mm)	34	55	80	95
H1(mm)	158	160	160	272

## Technical specification

### EA180 Servo drive

Item		Specification			
Basic specification	Control type	IGBT PWM control sine wave current driving			
	Feedback	Supporting incremental 2500 ppr encoder, 17 bit incremental encoder, 23 bit absolute encoder			
	Six (6) control modes	Speed control, position control, torque control, speed/position control, torque/speed control, position/torque control			
	Front panel	5 buttons, 5 LED places			
	Regenerative brake (note 1)	Built in braking unit and resistor, allowing to connect with the external braking resistor.			
	Use condition	Ambient temperature	Operating temperature 0~40°, storage temperature: -20° ~ 85°		
		Ambient humidity	Operating/storage: ≤90%RH (without condensation)		
		Altitude	≤1,000m		
		Vibration-resisting impact strength	Oscillation: ≤4.9m/s <sup>2</sup> (no work is allowed at the point of resonance); impact: ≤19.6m/s <sup>2</sup>		
		Protection degree	IP10		
Class of pollution	2				
Type of cooling (note2)	Fan cooling				
Performance	Speed torque control mode	Speed fluctuation ratio	Load variance: 0~100% load: 0.3% maximally Power voltage variance: Rated voltage ±10%: 0.3% maximally Ambient temperature: 0~50°: 0.3% maximally	On the basis of 23 bit encoder and at the rated speed	
		Speed ratio	1:3000 (2500ppr encoder) 1:5000 (17 bit and 23 bit encoder)		Continuous and stable operating at rated load: minimum speed/rated speed
		Frequency bandwidth	800Hz (17 bit encoder)		
	Torque control accuracy	±3% (current repeated accuracy)			
	Soft start time setting	0~30s (setting acceleration and deceleration respectively)			
	Position control mode	Feed-forward compensation	0~100% (setting the resolution 1%)		
		Positioning completion width	1~65535 command unit (setting the resolution 1 command unit)		
		Minimum setting time	5ms (no-load, when the positioning completes at the rated speed)		

### EA180 analog & pulse type servo drive

Item		Specification		
Speed torque control mode	Input signal	Command voltage	+10V resolution 12 bits (the motor rotates positively when there is positive command note3)	
		Input impedance	5.1 ohm approximately	
		Circuit constant	200μs	
Position control mode	Input signal	Command voltage	±10V resolution 12 bits	
		Input impedance	5.1 ohm approximately	
		Circuit constant	200μs	
Input/output signal	Position output	Multi-stage speed command	The default use of D15 (CMD0), D16 (CMD1), D17 (CMD2), D18 (CMD3) signal mix is used to realize 16-section speed selection	
		Command pulse	Input form	Differential drive: open-collector circuit
			Pulse form	Pulse + direction: orthogonal pulse : CW/CCW
			Input pulse frequency	Differential drive: max. 500kpps; open-collector circuit: max. 200kpps
		Command pulse wave filtration	Allowing to setting the pulse filtering parameters	
Input/output signal	Position output	Multi-stage position command	Allowing to set the D15 (CMD0), D16 (CMD1), D17 (CMD2), D18 (CMD3) signal mix to realize 16-section position selection (the one with the terminal capable of making CTRG trigger signal is provided separately). 16-section position progressive mode, using CTRG terminal single triggering	
		Command sliding mode	Lowpass filtering, moving-average filters	
Input/output signal	Position output	Internal open-collector power	+24V	
		Internal current-limiting resistance	Open-collector circuit: 2.2KΩ Differential drive: 200Ω	
Input/output signal	Position output	Output form	Phase A, B and Z: differential output Phase Z: OC output The pulse width of the Phase Z can be adjusted, max.3ms	
		Frequency dividing ratio	Random frequency dividing; the number of frequency dividing can be the one of 4 times before frequency or after frequency.	

Note1:without built-in brake resistor below 2R8

Note2:natural cooling below 2R8

Note3:face to shaft, shaft anticlockwise rotation is positive rotation.

Item		Specification	
Input/output signal	Digital input	Modifiable signal distribution	8-way DI Servo enabled, fault resetting, position pulse error counter clearing, speed command direction selection, position/speed multi-stage switch, zero-position fixing enabled, internal command triggering, control mode switch, pulse inhibited, positive drive inhibited, Negative drive inhibited, second torque limit, positive inching, negative inching, others
		Modifiable signal distribution	4-way DO Servo ready, brake output, motor rotary output, zero-speed signal, speed proximity, speed arrival, position proximity, position arrival, torque limit, speed limit, warning output, fault output, others
Internal functions	Overrun prevention function	Origin return	P-OT, N-OT take effect, deceleration stop Optional 35 origin return modes
		Electronic gear ratio	N/M time N: 1~65535 M: 1~65535 Allowing to switch the molecule of 4 types of electronic gear ratios via terminal
	LED display	5-bit LED display: main circuit CHARGE	
	Protection function	Overvoltage, undervoltage, overcurrent, overspeed, IGBT overheat, overload, encoder abnormality, large position error, EEPROM fault, others	
	Analog quantity output for observation	2-way AO: DC0~10V, maximum output current: 1mA Allowing to set the observation object	
	Communication function	Communication mode	RS232, RS485
Others	Communication protocol	Modbus RTU.	
		Two-stage gain switch, automatic gain adjustment, 4 groups of alarm records, JOG operation	

■ EA180E EtherCAT network type Servo drive

Item		Specification
Input/output signal	Digital input	8-way DI Servo enabled, fault resetting, position pulse error counter clearing, speed command direction selection, position/speed multi-stage switch, zero-position fixing enabled, internal command triggering, control mode switch, pulse inhibited, positive drive inhibited, Negative drive/inhibited, second torque limit, positive inching, negative inching, others
	Digital output	4-way DO Servo ready, brake output, motor rotary output, zero-speed signal, speed proximity, speed arrival, position proximity, position arrival, torque limit, speed limit, warning output, fault output, others
Internal functions	Overrun prevention function	P-OT, N-OT take effect, deceleration stop
	LED display	5-bit LED display: main circuit CHARGE
	Protection function	Overvoltage, undervoltage, overcurrent, overspeed, IGBT overheat, overload, encoder abnormality, large position error, EEPROM fault, others
Communication functions	Others	Two-stage gain switch, automatic gain adjustment, 4 groups of alarm records, JOG operation
	Communication mode	RS232, EtherCAT
	EtherCAT bus communication	Synchronizing cycle: 1ms or its integral multiple Supporting COE protocol and the following operation modes: Profile position mode Profile velocity mode Profile torque mode Interpolation position mode Cyclic synchronous position mode Cyclic synchronous velocity mode Cyclic synchronous torque mode Homing mode

■ EA180C CANopen network Servo drive

Item		Specification
Input/output signal	Digital input	8-way DI Servo enabled, fault resetting, position pulse error counter clearing, speed command direction selection, position/speed multi-stage switch, zero-position fixing enabled, internal command triggering, control mode switch, pulse inhibited, positive drive inhibited, Negative drive/inhibited, second torque limit, positive inching, negative inching, others
	Digital output	4-way DO Servo ready, brake output, motor rotary output, zero-speed signal, speed proximity, speed arrival, position proximity, position arrival, torque limit, speed limit, warning output, fault output, others
Internal functions	Overrun prevention function	P-OT, N-OT take effect, deceleration stop
	LED display	5-bit LED display: main circuit CHARGE
	Protection function	Overvoltage, undervoltage, overcurrent, overspeed, IGBT overheat, overload, encoder abnormality, large position error, EEPROM fault, others
Communication functions	Others	Two-stage gain switch, automatic gain adjustment, 4 groups of alarm records, JOG operation
	Communication mode	RS232, RS485, CANopen
	EtherCAT bus communication	Synchronizing cycle: 1ms or its integral multiple Supporting the following operation modes: Profile position mode Profile velocity mode Profile torque mode Homing mode

SER series servo motor model number description

SER 08 - 0R7- 30- 2 F A Y 1 -XX

①	②	③	④	⑤	⑥	⑦	⑧	⑨	⑩
<b>Position 1 - series</b> SER: standard servo motor SES: high-performance servo motor (to be released)	<b>Position 2 - motor flange size</b> 04: 40mm 06: 60mm 08: 80mm 09: 86mm	<b>Position 3 - motor's rated output power</b> OR1: 100W OR2: 200W OR4: 400W OR7: 750W OR8: 850W 1R0: 1000W 1R2: 1200W 1R3: 1300W 1R5: 1500W 1R8: 1800W 2R0: 2000W 3R0: 3000W 4R0: 4000W 4R3: 4300W 4R5: 4500W 5R6: 5600W 7R5: 7500W							
<b>Position 4 - motor's rated speed</b> 10: 1000rpm 15: 1500rpm 20: 2000rpm 25: 2500rpm 30: 3000rpm	11: 110mm 13: 130mm 18: 180mm	<b>Position 7 - type of inertia</b> A: low inertia B: intermediate inertia C: high inertia							
<b>Position 5 - voltage classes</b> 2: 220V 3: 380V	<b>Position 8 - shaft end</b> Y: with the U-type key slot, with the screw holes(notel) Z: with the double round key slots, with the screw holes								
<b>Position 6 - type of encoder</b> A: 2500 ppr incremental encoder B: 17 bit incremental encoder F: 23 bit absolute value encoder	<b>Position 9 - type selection</b> Empty: no selection 1: with brake (DC24V) 2: with oil seal 3: with brake and oil seal								
									<b>Position 10 - special specification</b>

Note: some products may have the double-cyclic key slots; except for 130 flange motor, the width and height of key is as same as that of the U-shape key slot.

SER servo motor – common characteristics

Motor's insulation class	F class
Voltage resistance of insulation	1500V 60s
Insulation resistance	DC500V, 10MΩ or above
Motor's temperature resistance class	B
Degree of protection	Totally closed self-cooling IP 65 (except for shaft through part)
Operating environment	Ambient temperature: 0 - 40°C Relative humidity: 20 - 80% (without condensation)
Installation mode	Flange installation
Direction of rotation	Anticlockwise (CCW) rotation when watching from the load side under the positive rotation command.

Keeping Brake specification

Motor flange size	40	60	80	86	110	130	180	180
Rated voltage	DC 24-26.4V							
Static friction torque	0.35 N.m	2 N.m	3 N.m	3 N.m	10 N.m	20 N.m	40 N.m	80 N.m
Rated power * note	3.5W	6.3W	10.4W	10.4W	11.6W	19.5W	25W	49W
Sealing voltage	18V DCmax							
Release voltage	1.5V DCmin							
Rated action time	150ms							

Note: the rated power tolerance is ±7%; the power value is 49W; however it is only limited to 7.5kW servo motor.

- The keeping brake will only keep the motor locked after power off. It can not be used to brake motor when motor is running.
- The 24V power supply required by the keeping brake should be provided by user independently; the 24V power supply of the drive can not be used for the keeping brake absolutely.
- The action time of the keeping brake varies according to different the circuit; it should be confirmed according to the product.
- The static friction torque is the one provided by the brake when the motor stops and keeps still; if there is external impact, there is no guarantee to keep the motor still.

## SER series servo motor installation size

### ■ 40, 60, 80, 86 flange servo motor

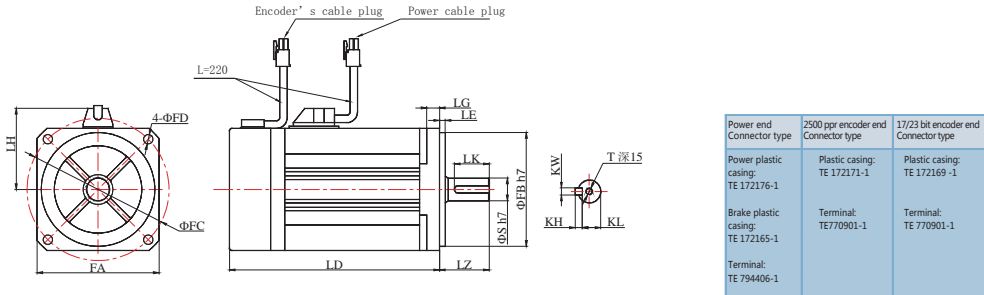

Motor model number	LD (mm)	FA (mm)	FB (mm)	FC (mm)	FD (mm)	LZ (mm)	LK (mm)	LE (mm)	LG (mm)	LH (mm)	LM (mm)	LT (mm)	S (mm)	KL (mm)	KH (mm)	KW (mm)	T (mm)	Mass (kg)
SES04-OR1-30-□□□□□	100.5(133.5)	40	30	46	4.5	25.5	14	3	8	35	-	-	8	6.3	3	3	M3	0.47 (0.67)
SER06-OR2-30-□□□□□	113.5 (147)	60	50	70	5.5	30	22.5	3	8	44	-	-	14	11	5	5	M5	1.01(1.40)
SER06-OR4-30-□□□□□	134(168)	60	50	70	5.5	30	22.5	3	8	44	-	-	14	11	5	5	M5	1.37 (1.78)
SER08-OR7-30-□□□□□	141.5(173)	80	70	90	6.5	35	25	3	8	55	-	-	19	15.5	6	6	M5	2.47 (3.33)
SER08-OR7-20-□□□□□	171.5(203)	80	70	90	6.5	35	25	3	8	55	-	-	19	15.5	6	6	M5	3.40 (4.10)
SER08-1R0-30-□□□□□	171.5(203)	80	70	90	6.5	35	25	3	8	55	-	-	19	15.5	6	6	M5	3.40 (4.10)
SER09-OR7-30-□□□□□	148(183)	86	80	100	6.5	35	25	3	9	58	-	-	16	13	5	5	M5	3.24 (3.94)

### ■ 180mm flange servo motor

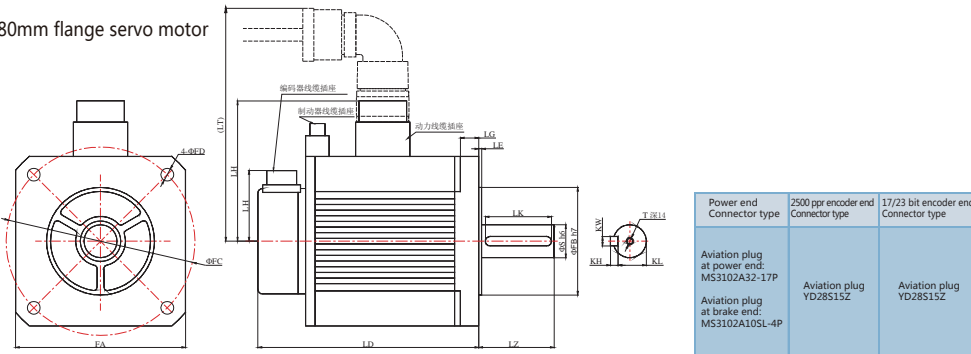

Motor model number	LD (mm)	FA (mm)	FB (mm)	FC (mm)	FD (mm)	LZ (mm)	LK (mm)	LE (mm)	LG (mm)	LH (mm)	LM (mm)	LT (mm)	S (mm)	KL (mm)	KH (mm)	KW (mm)	T (mm)	Mass (kg)
SER18-3R0-15-□□□□□	173.5(222)	180	114.3	200	13.5	79.9	70	3	19.5	-	150	230	35	38	8	10	M8	13.5 (18.50)
SER18-3R0-15-□□□□□	202.5(251)	180	114.3	200	13.5	79.9	70	3	19.5	-	150	230	35	38	8	10	M8	17.7 (22.60)
SER18-4R5-15-□□□□□	202.5(251)	180	114.3	200	13.5	79.9	70	3	19.5	-	150	230	35	38	8	10	M8	17.7 (22.60)
SER18-5R6-15-□□□□□	252.5(323.5)	180	114.3	200	13.5	79.9	70	3	19.5	-	150	230	35	38	8	10	M8	25.6 (33.60)
SER18-7R5-15-□□□□□	312.5(392.5)	180	114.3	200	13.5	79.9	70	3	19.5	-	150	230	35	38	8	10	M8	34.9 (42.90)

### ■ 110, 130 flange servo motor

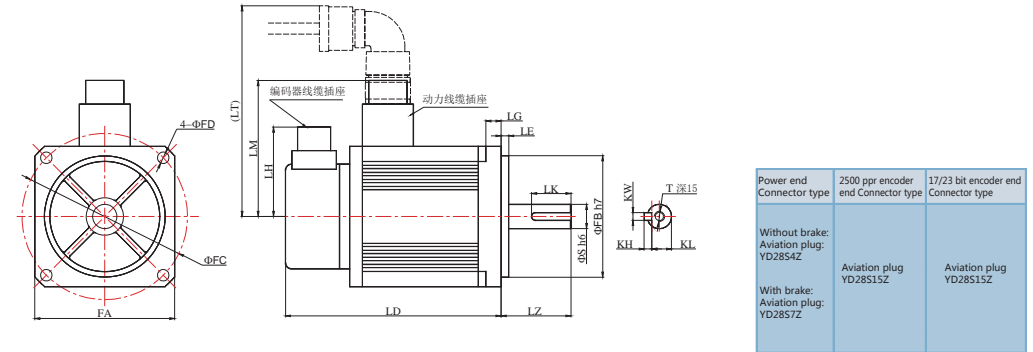

Motor model number	LD (mm)	FA (mm)	FB (mm)	FC (mm)	FD (mm)	LZ (mm)	LK (mm)	LE (mm)	LG (mm)	LH (mm)	LM (mm)	LT (mm)	S (mm)	KL (mm)	KH (mm)	KW (mm)	T (mm)	Mass (kg)
SER11-OR6-30-□□□□□	155.5(210.5)	110	95	130	9	55	31	6	9	-	107	176	19	15.5	6	6	M6	3.93(5.39)
SER11-1R0-20-□□□□□	205.5(260.5)	110	95	130	9	55	31	6	9	-	107	176	19	15.5	6	6	M6	6.42(7.88)
SER11-1R2-30-□□□□□	185.5(240.5)	110	95	130	9	55	31	6	9	-	107	176	19	15.5	6	6	M6	5.46(6.92)
SER11-1R8-30-□□□□□	218.5(273.5)	110	95	130	9	55	31	6	9	-	107	176	19	15.5	6	6	M6	7.26(8.72)
SER13-OR7-20-□□□□□	150(205)	130	110	145	9	58	45	6	12	-	117	186	22	18	7	8	M6	5.20(6.90)
SER13-1R0-10-□□□□□	215(270)	130	110	145	9	58	45	6	12	-	117	186	22	18	7	8	M6	10.12(11.67)
SER13-1R0-20-□□□□□	165(220)	130	110	145	9	58	45	6	12	-	117	186	22	18	7	8	M6	6.41(7.94)
SER13-1R0-30-□□□□□	150(205)	130	110	145	9	58	45	6	12	-	117	186	22	18	7	8	M6	5.31(6.89)
SER13-1R5-10-□□□□□	265(320)	130	110	145	9	58	45	6	12	-	117	186	22	18	7	8	M6	13.82(15.40)
SER13-1R5-20-□□□□□	185(240)	130	110	145	9	58	45	6	12	-	117	186	22	18	7	8	M6	7.89(9.43)
SER13-1R5-30-□□□□□	165(220)	130	110	145	9	58	45	6	12	-	117	186	22	18	7	8	M6	6.40(7.96)
SER13-2R0-20-□□□□□	215(270)	130	110	145	9	58	45	6	12	-	117	186	22	18	7	8	M6	10.12(11.67)
SER13-2R0-30-□□□□□	185(240)	130	110	145	9	58	45	6	12	-	117	186	22	18	7	8	M6	7.85(9.47)
SER13-3R0-20-□□□□□	265(320)	130	110	145	9	58	45	6	12	-	117	186	22	18	7	8	M6	13.81(15.34)
SER13-3R0-30-□□□□□	215(270)	130	110	145	9	58	45	6	12	-	117	186	22	18	7	8	M6	10.12(11.67)

Note: The value in the brackets is the data of the one with the keeping brake.

## SER series servo motor torque and speed characteristic curve graph

### 40, 60, 80 flange servo motor torque and speed characteristic curve graph

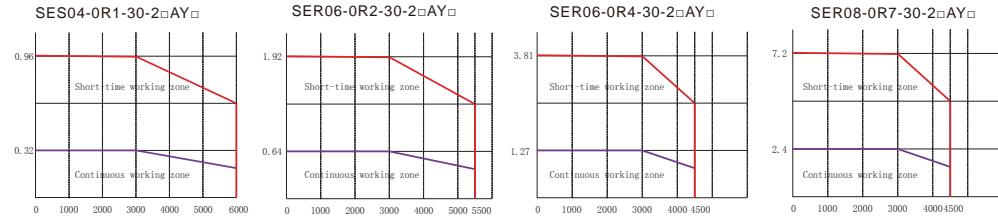

### 110, 130 flange servo motor torque and speed characteristic curve graph

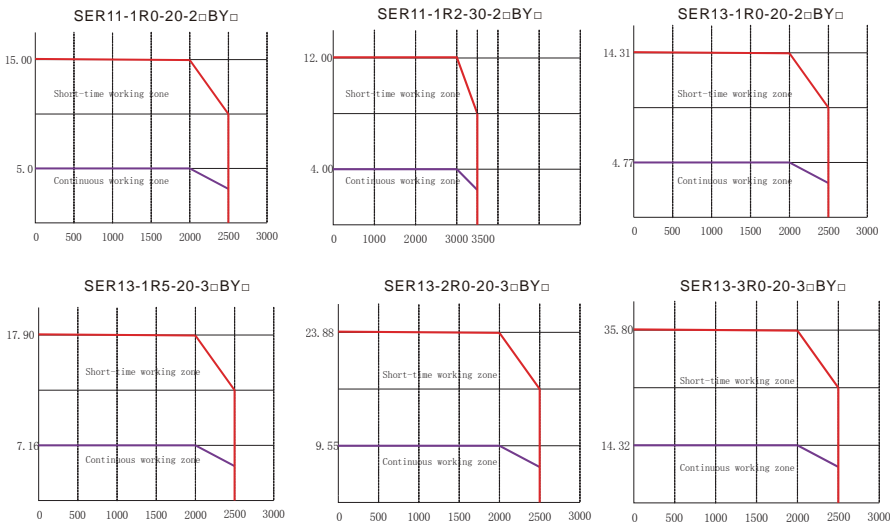

### 180mm flange servo motor torque and speed characteristic curve graph

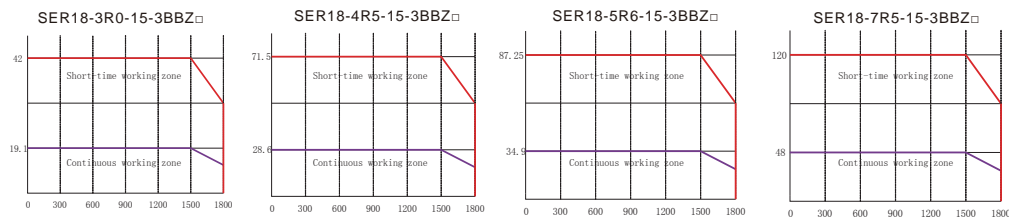

## SER series servo motor parameter table



Servo motor model	Voltage	Rated power (W)	Rated speed (rpm)	Max. speed (rpm)	Rated current (A)	Instantaneous maximum current	Rated torque (Nm)	Instantaneous maximum torque	Torque constant	Rotational inertia (Kg.m <sup>2</sup> *10 <sup>-4</sup> )	Adapting driver
SES04-0R1-30-2□AY□	AC 220	100	3000	6000	1.1	3.3	0.32	0.96	0.29	0.04(0.04 <sup>*1</sup> )	1R6-1□
SER06-0R2-30-2□AY□		200	3000	5500	1.2	3.6	0.64	1.92	0.53	0.18(0.18 <sup>*1</sup> )	2R5-1□
SER06-0R4-30-2□AY□		400	3000	4500	2.3	6.9	1.27	3.81	0.55	0.3(0.3 <sup>*1</sup> )	
SER08-0R7-30-2□AY□		750	3000	4500	4.3	12.9	2.4	7.20	0.56	1.01(1.02 <sup>*1</sup> )	5R5-2□
SER08-0R7-20-2□AY□ <sup>*2</sup>			2000	3000	3.0	9.0	3.5	10.50	1.17	1.59(1.6 <sup>*1</sup> )	
SER09-0R7-30-2□BZ□ <sup>*3</sup>			3000	4000	3.4	10.2	2.4	7.20	0.71	2.42(2.43 <sup>*1</sup> )	
SER13-0R7-20-2□CY□			2000	2500	3.88	11.6	3.65	10.95	0.94	6.17(6.19 <sup>*1</sup> )	
SER11-0R6-30-2□BY□ <sup>*3</sup>		600	3000	4000	2.5	7.5	2.0	6.00	0.8	3.03(3.05 <sup>*1</sup> )	2R5-1□
SER11-1R2-30-2□BY□ <sup>*3</sup>		1200	3000	3500	4.9	14.7	4.0	12.00	0.82	5.54(5.56 <sup>*1</sup> )	7R6-2□
SER11-1R8-30-2□BY□ <sup>*3</sup>		1800	3000	3500	6.6	19.8	6.0	18.00	0.91	8.55(8.57 <sup>*1</sup> )	
SER08-1R0-30-2□AY□		1000	3000	4000	4.0	12.0	3.5	10.50	0.88	1.59(1.6 <sup>*1</sup> )	5R5-2□
SER11-1R0-20-2□BY□ <sup>*3</sup>			2000	2500	5.0	15.0	5.0	15.00	1.0	7.22(7.24 <sup>*1</sup> )	7R6-2□
SER13-1R0-10-2□BY□			1000	1500	4.72	14.2	9.55	28.65	2.02	17.14(17.16 <sup>*1</sup> )	
SER13-1R0-10-2BBZ			1000	1500	4.72	14.2	9.55	28.65	2.02	17.14	
SER13-1R0-20-2□BY□			2000	2500	4.72	14.2	4.77	14.31	1.01	8.71(8.73 <sup>*1</sup> )	
SER13-1R0-30-2□BY□			3000	3500	4.96	14.9	3.27	9.81	0.66	6.17(6.19 <sup>*1</sup> )	
SER13-1R5-20-2□BY□	2000		2500	6.87	20.61	7.16	21.48	1.042	12.08(12.10 <sup>*1</sup> )	010-2□	
SER13-1R5-10-3□BY□	1000		1500	6.76	16.9	14.32	35.80	2.12	25.58(25.6 <sup>*1</sup> )	8R4-3□	
SER13-1R5-20-3□BY□	2000	2500	4.1	10.3	7.16	17.90	1.75	12.08(12.1 <sup>*1</sup> )	5R4-3□		
SER13-1R5-30-3□BY□	3000	3500	6.4	16.0	4.78	11.95	0.75	8.71(8.73 <sup>*1</sup> )			
SER13-2R0-20-3□BY□	2000	2000	2500	6.5	16.3	9.55	23.88	1.47	17.14(17.16 <sup>*1</sup> )	8R4-3□	
SER13-2R0-30-3□BY□		3000	3500	5.8	14.5	6.5	16.25	1.12	12.08(12.1 <sup>*1</sup> )		
SER13-2R0-20-3BBZ1		2000	2500	6.5	19.5	9.55	28.65	1.469	17.16		
SER13-3R0-20-3□BY□	AC 380	2000	2500	9.6	24.0	14.32	42.96	1.49	25.58(25.6 <sup>*1</sup> )	012-3□	
SER13-3R0-20-3BBZ□		2000	2500	9.6	28.8	14.32	42.96	1.49	25.58(25.6 <sup>*1</sup> )		
SER13-3R0-30-3□BY□		3000	3500	8.3	20.8	9.55	23.88	1.15	17.14(17.16 <sup>*1</sup> )		
SER18-3R0-15-3FBZ□		1500	1800	11.5	28.8	19.1	42.00	1.66	25.95(26.22 <sup>*1</sup> )	012-3B	
SER18-3R0-15-3FCZ□				7.5	18.8	19.1	47.75	2.55	45.51(45.78 <sup>*1</sup> )		
SER18-4R5-15-3FBZ□				11.0	27.5	28.6	71.50	2.6	45.51(45.78 <sup>*1</sup> )		
SER18-5R6-15-3FBZ□				15.0	37.5	34.9	87.25	2.33	79.89(81.01 <sup>*1</sup> )		
SER18-7R5-15-3FBZ□				20.3	50.8	48.0	120.00	2.36	120.36(121.48 <sup>*1</sup> )		
	7500										

#### Notes:

- The values in the brackets is the rotational inertia of the one with the brake.
- As for 17 bit incremental type, the one with the band-type brake is available for supply.
- Currently 2500 ppr and 17 bit incremental type are corresponding.
- If there is oil seal, please reduce the rated value by 10%.

## EA180 series servo product – optional part

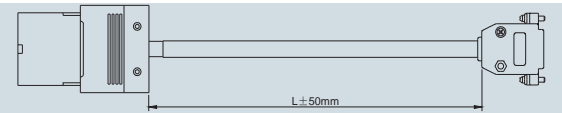
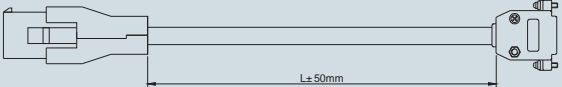
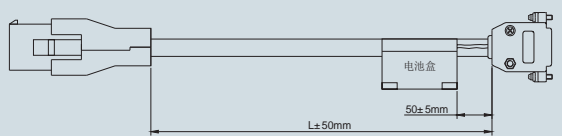
### Servo motor encoder cable

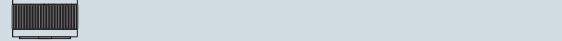
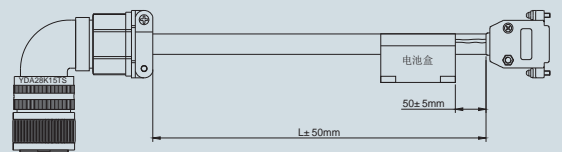
Motor flange size	Type	Model Number	Dimensional drawing
40/60/80/86	2500 ppr Encoder cable	A10-LP-A000-m	
	17 bit incremental Encoder cable	A10-LS-A000-m	
	23 bit absolute value Encoder cable	A10-LA-A000-m	
110/130/180	2500 ppr Encoder cable	A10-LP-H100-m	
	17 bit incremental Encoder cable	A10-LS-H100-m	
	23 bit absolute value Encoder cable	A10-LA-H100-m	

\*: m is the length of cable; its standard specification is 3.0, 5.0, 7.0 and 9.0; each of which refers to the length of 3.0m, 5.0m, 7.0m, 9.0m.

### Servo motor power cable

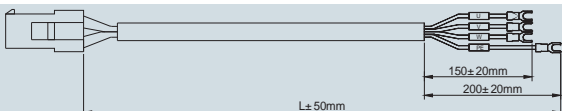
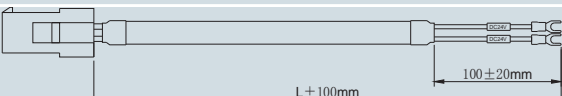
Motor flange size	Type	Model Number	Dimensional drawing
40/60/80/86	Power cable	A10-LM-A010-m	
	Braking cable	A10-LZ-A005-m	

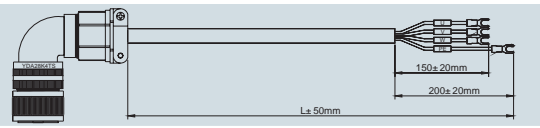
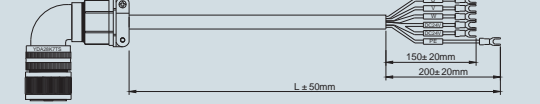
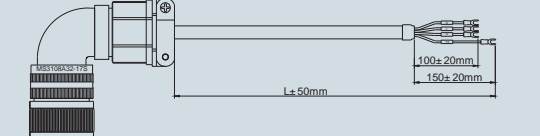
Motor flange size	Type	Model Number	Dimensional drawing
110/130	Power cable without brake	A10-LM-H120-m	
	Power cable with brake	A10-LB-H120-m	
180	Power cable	( 3\4.5kW ) A10-LM-M220-m ( 5.6\7.5kW ) A10-LM-M240-m	

\*: m is the length of cable; its standard specification is 3.0, 5.0, 7.0 and 9.0; each of which refers to the length of 3.0m, 5.0m, 7.0m, 9.0m.

### Servo drive communication cable

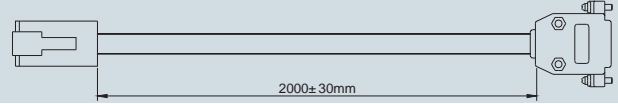
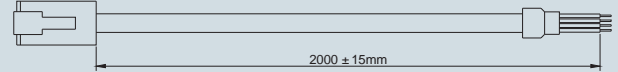
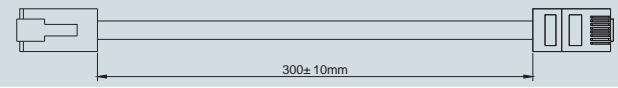
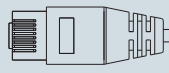
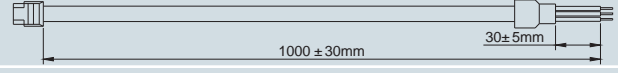
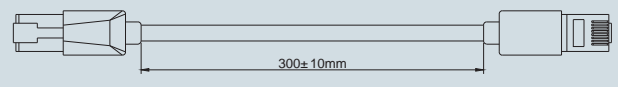
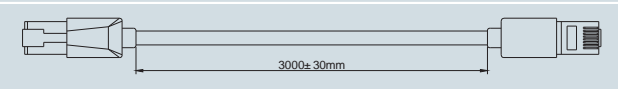
Servo drive	Description	Model Number	Dimensional drawing
EA180	PC and Servo drive RS232 communication cable	A10-T5-2.0	
	PLC and Servo drive CAN and RS485 communication cable	A10-T2-2.0	
	Servo drive CAN and RS485 multi-unit parallel connection cable	A10-T1-0.3	
	Servo drive CAN and RS485 communication terminal – matching resistance	A10-T3	
	Analog quantity output cable	A10-A0-1.0	
EA180E	EtherCAT multi-unit parallel connection cable	A10-T4-0.3	
	EtherCAT controller and Servo drive communication cable	A10-T4-3.0	
	PC and Servo drive RS232 communication cable	A10-T0-2.0	